

AX Unit User and Maintenance Manual

INSTALLATION PROCEDURE	Page 2
CHECKS TO BE PERFORMED AFTER INSTALLATION	4
PRECAUTIONS FOR CORRECT OPERATION	6
AP Unit Operating Cycle	6
STROKE ADJUSTMENT METHODS	8
FAULTY OPERATION	10
OPERATIONAL MAINTENANCE	11
Topping up procedure for units without external tank	11
Topping up procedure for units with external tank	12
UNSCHEDULE D MAINTENANCE	14
Gasket installation diagram for AX0840 - AX0950 units	15
Gasket replacement procedure for AX0840 - AX0950 units	16
Gasket installation diagram for AX1063 - AX1180 - AX12100 - AX13125 units	18
Gasket replacement procedure for AX1063 - AX1180 - AX12100 - AX13125 units	19
Gasket installation diagram for AX14160 - AX15200 - AX16200 units	22
Gasket installation procedure for AX14160 - AX15200 - AX16200 units	23
Gasket replacement on AX0840 - AX0950 unit pressure relief valve	26
Gasket replacement on AX1063 - AX1180 - AX12100 - AX13125 unit pressure relief valve	27
Gasket replacement on AX14160 - AX15200 unit pressure relief valve	28
Gasket replacement during mechanical adjustment	29
LIST OF GASKETS FOR AP EUP UNIT	30

AX Unit User and Maintenance Manual

INSTALLATION PROCEDURE

- All AX power units are supplied complete with Vanguard ATF Dexron II hydraulic oil.



Warning

To prevent oil emulsion problems, the AX units are supplied with oil above the maximum level allowed. Drain off excess oil following the instructions given on page 5 before carrying out pneumatic connection. Failure to perform this operation could cause serious damage to the unit's hydraulic circuits.

- The compressed air for driving the unit must be filtered and lubricated, and it must absolutely never exceed a maximum pressure of 6 bar.
- Check to make sure that pipes are clean during connection so that no foreign bodies can get into the circuits, thus jeopardizing the correct operation of the unit.
- Check that the couplings and pipes used to connect the unit have a section that is appropriate for that type of unit. Inappropriate couplings and pipes will slow down work speed.

We recommend using pipes with the following diameters for oil circulation in our units:

UNIT	INTERNAL DIAM.(mm)
AX 0840	6
AX 0950	6
AX 1063	8
AX 1180	8
AX 12100	10
AX 13125	10
AX 14160	12
AX 15200*	12

(*) AX15200 = AX16200 (12 mm)

- The pneumatic valves used must have a flow proportional to the internal diameters of pipes.

AX Unit User and Maintenance Manual

Do not allow the unit's stem to rotate during the connection of equipment and dies.

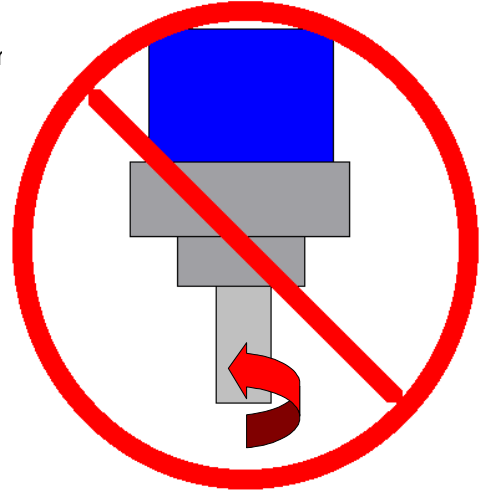

AX Unit User and Maintenance Manual

CHECKS TO BE PERFORMED AFTER INSTALLATION

1 After performing pneumatic connection, check that connections are pressurized with the unit at rest:

- Connections 1 and 3 = Pressure at 6 bar
- Connections 2 and 4 = Discharge
- Connection 5 = Pressure at 2.5 bar

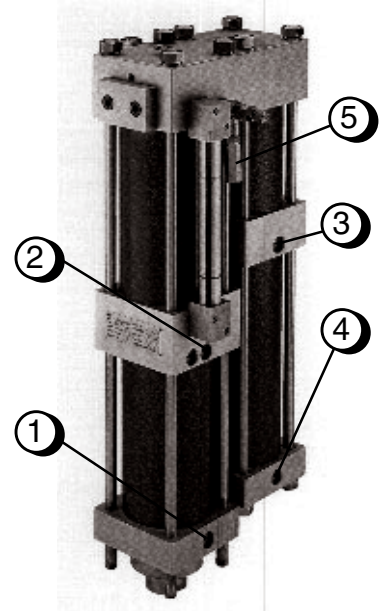

2 Check oil tank pressure (connection 5) in all units that require this operation. Set the pressure governor to 2.5 Bar and slowly unscrew the knurled knob on the connection to bleed off any excess pressure. Screw the knob back on until completely sealed again.

3 Check the oil level by measuring it with the unit's stem held back and with the tank indicating a maximum pressure of 2.5 Bar. The amount of oil contained in the unit must not exceed maximum level. Any excess must be drained. The oil is drained off by following the procedure described below :

AX Unit without external tank

- Let off unit pressure.
- Bleed off any residual pressure by unscrewing the knurled knob on the blow-off valve. .
- Unscrew the drain plug and let excess oil flow out.

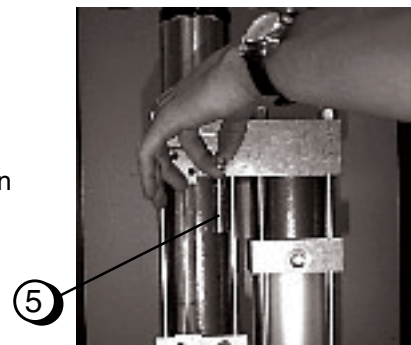

AX Unit User and Maintenance Manual

AX Unit with External Tank

- * Let off unit pressure
- * Release residual pressure by loosening the bleeder valve's knurled knob, located at the top of tank.
- * Unscrew the drain plug and let excess oil drain out (pos. 1).

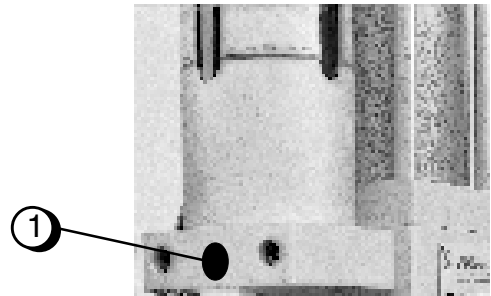
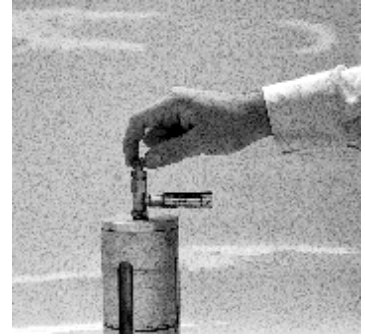

- Check for any oil emulsion due to the formation of air bubbles inside the unit during handling and transportation, which causes fluid to emulsify during operation. Perform at least two bleeding operations separating each with 10-15 cycles of approach stroke only, following the directions below.
- When the unit is installed vertically (rod turned downward), the emulsion is eliminated by slanting the unit about 30° to the side with the sinters on the dual body (pos. 9-10) facing upward. Loosen these by a few turns to allow air to bleed off, and re-tighten as soon as a small amount of oil flows out. Unscrew the oil filler cap (pos. 12) applying this same procedure and slanting the unit about 80°; be careful not to exceed this angle by too much to keep large amounts of oil from leaking out.
- When the unit is equipped with an external tank, bleeding is performed by slanting the unit about 30° (with the plugs in pos. 13-14 facing upward). Unscrew slowly (no more than two turns) and let out air and a small amount of oil. Then re-tighten to make airtight.
- When the unit is installed vertically (with rod turned upward), the emulsion is eliminated by slanting the unit about 30° (to the side with the sinters (pos. 1-8) turned upward). Unscrew these to allow any air present to bleed off and re-tighten them as soon as a small amount of oil leaks out. Unscrew the oil filler cap on the relative circuit about 180°, applying this same procedure and being careful not to slant by more than this value to keep large amounts of oil from leaking out.

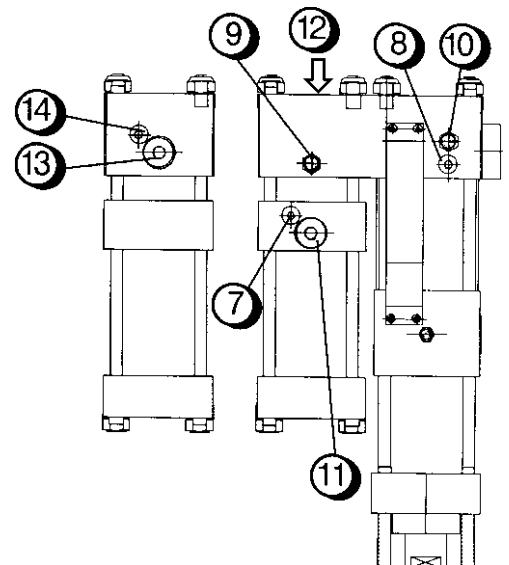

PRECAUTIONS FOR CORRECT OPERATION

- The compressed air for feeding the unit must be filtered and dehumidified.
- The compressed air for feeding the unit must be filtered and dehumidified.
- After installation, check the unit's operating cycle, keeping in mind that it consists of three separate phases:

AX Type Unit Operating Cycle

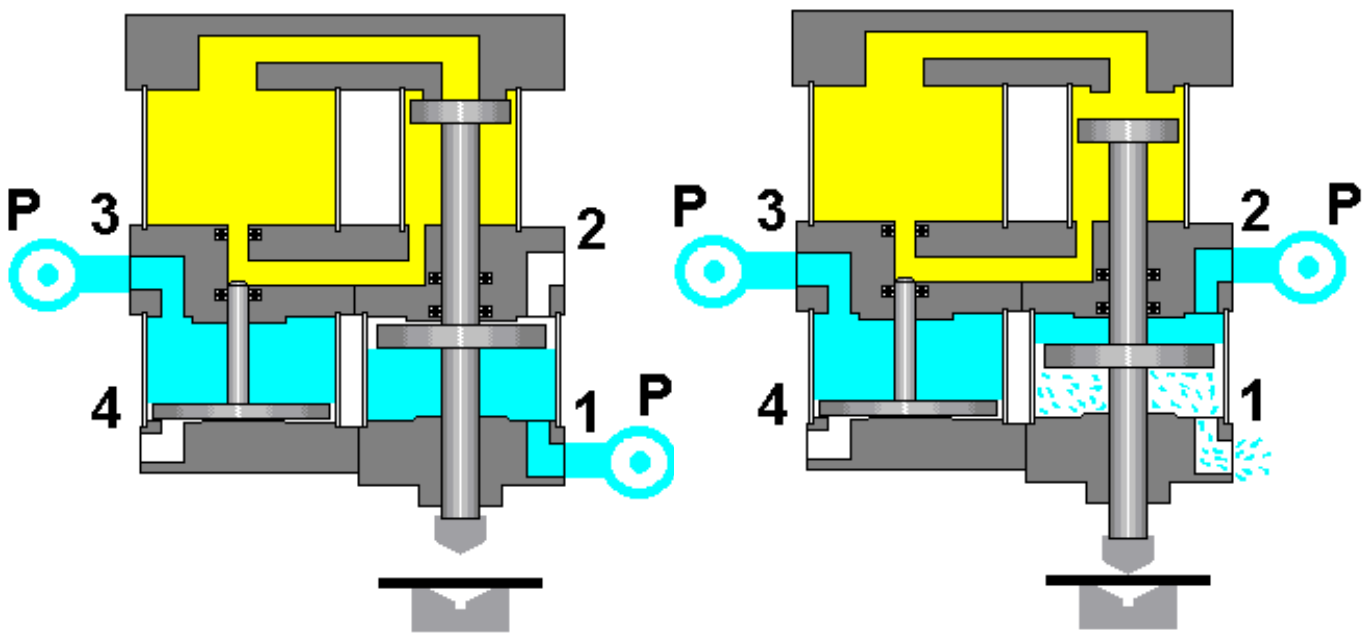

1ST PHASE

The rod is completely pulled back.
This condition must be restored at
the end of each work cycle.

Switching of approach valve.
The unit's rod must reach and
support the item to be machined.

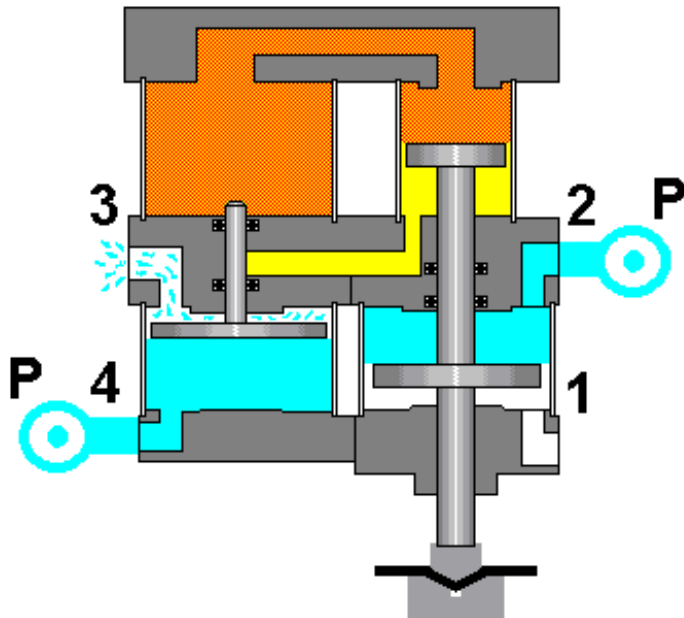

2nd PHASE

Switching of the work stroke valve.
The unit performs the work stroke
by executing the machining
operation for which is has been
preset.

SISTEMI DI REGOLAZIONE DELLA CORSA

Volumetric adjustment of work stroke by means of modulating valve (AP units)

Work stroke modulating valve allows to pre-set the work stroke value by manual adjustment thus optimizing the unit work and replacing external mechanical locks. The system has been designed so that pre-set work strokes can be used in any point of the approaching stroke. Adjustment is carried out by rotating the knurled knob and checking the set work stroke on the nonius. To a clockwise rotation corresponds a work stroke increase whereas to an anticlockwise rotation corresponds a work stroke decrease.

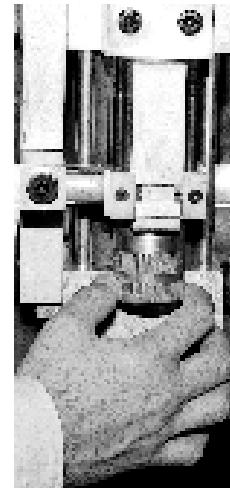

Mechanical stroke regulation

The mechanical regulation of the stroke enables the variation of both the lower dead center (with a regulation range of 0 to 60mm.) and the upper dead center (with a regulation range of 0 to 115mm.) to suit working requirements:

- To regulate the U.D.C. loosen the nut on the regulation collar (pos. 1) and move the collar (pos. 2) using a key. Rotation of the collar in a clockwise direction reduces the U.D.C., while rotation in an anticlockwise direction increases it.
- To regulate L.D.C. loosen the locking collar (pos. 3) and turn the special regulation flywheel. Rotation in a clockwise direction reduces the L.D.C., while rotation in an anticlockwise direction increase it.

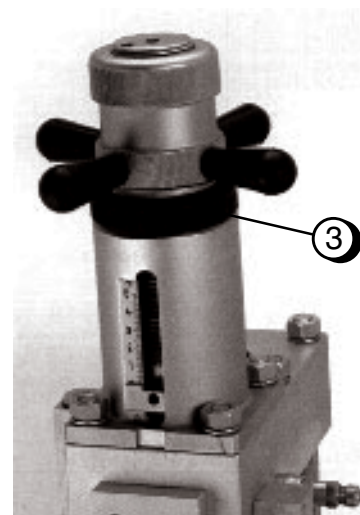
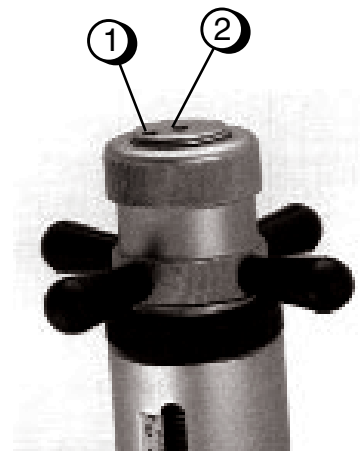

AX Unit User and Maintenance Manual

Electronic stroke management

The system, composed of a linear potentiometer incorporated in the power unit measures the movement values and enables the electronic management of the production cycle. The regulatory methods are closely linked with customer application requirements (see electrical - pneumatic diagram)

Magnetic model

By means of electronic sensors, it allows to identify the final or intermediate position of the pistons, ensuring an electronic management of the different phases of the operating cycle (sensor features and electric connection - see page 30)



Return stroke decelerator

By rotating decelerator screw clockwise the unit decelerating intensity increases while an anticlockwise rotation decreases it. The capacity of absorbing energy means avoiding stress to the machine structure and limiting noise.



AX Unit User and Maintenance Manual

OPERATING FAULTS DUE TO INCORRECT INSTALLATION OR WORK CYCLE

FAULT NOTED	CAUSE OF FAULT
<p>The rod slows down during the approach stroke and does not begin the work stroke.</p> <p>The work stroke does not begin or begins only partially.</p> <p>The oil in unit tends to emulsify.</p> <p>During the return stroke, the rod tends to slow down and stop before reaching the upper dead center</p>	<p>The cause of fault is the early start up of the work stroke ahead of the operating cycle</p> <p>1) Early start-up of work stroke ahead of the operating stroke. 2) Emulsified oil 3) The rod has already reached end-of-stroke.</p> <p>The cause is the eraly start-up of work stroke ahead of the operating stroke.</p> <p>This fault may be caused by:</p> <p>1) Too much oil in tank. 2) Closed deceleration adjustment screw 3) Too much pressure in tank.</p>

- * There may be an incorrect stroke adjustment during the initial phase of rod return. This phenomenon is due to the different speeds of the approach stroke and of the work stroke. It is eliminated by applying a quick-release valve to connection no. 4.

AX Unit User and Maintenance Manual

OPERATIONAL MAINTENANCE

The AX series power units maintain their operating characteristics unvaried over time without requiring any special maintenance operations. Only two important operations need to be performed periodically:

- Periodic lubrication of moving parts.
- Continuous checks of power unit oil supply. Top up when the level indicator drops below the minimum level.



Precautions

- With extended hours of operation, the oil contained in the unit may change color and become darkbrown. This phenomenon, which is due mostly to the oil coming into contact with the rubber nitril joints, does not compromise correct operation, and therefore, the unit's reliability, in any way.
- The oil circulating in the unit maintains its characteristics unvaried even after extensive periods of use, compatibly with the duration of joints. Its replacement is not foreseen. For correct operation, however, it is very important to top up each time the oil level drops below the minimum level indicator mark.

Topping Up of Unit without External Tank



- Eliminate unit feeding pressure.
- Bleed any residual pressure from the power unit by turning the knurled knob on connection no. 5 in the counterclockwise direction, then unscrew and remove.



- Remove the filler cap from the top of the dual body.



- Fill the line with the type of oil specified on the table attached to unit.

AX Unit User and Maintenance Manual

Topping Up of Unit with External Tank



- Eliminate unit feeding pressure.
- Bleed residual pressure from the power unit by turning the knurled knob on connection no. 5 in the counterclockwise direction, then unscrew and remove.

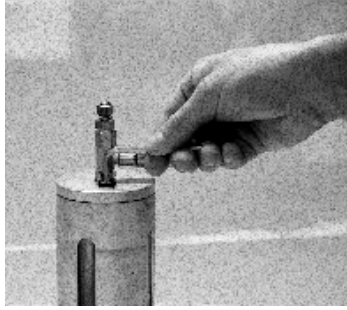

- Remove the filler cap at the top of the dual body by turning in the counterclockwise direction.

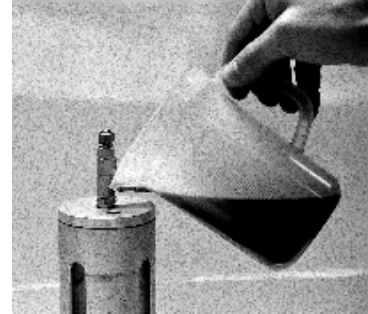

- Fill the line with the type of oil specified on the table attached to unit.

AX Unit User and Maintenance Manual

Amount of Oil To Be Poured

- If the unit's rod is still in resting position (pulled back), pour oil until it reaches the maximum level marked on indicator.
- If the unit's rod is still in stop position, pour oil until it is midway between the minimum and maximum levels marked on the indicator.
- Filling the unit with too much oil would cause a slowdown during the rod's return stroke. Perform the following operations to remove excess oil:
 - 1 Eliminate pressure from unit.
 - 2 Bleed off residual pressure.
 - 3 Loosen the drain plug and let excess oil flow out. Re-tighten until air-tightness is restored.

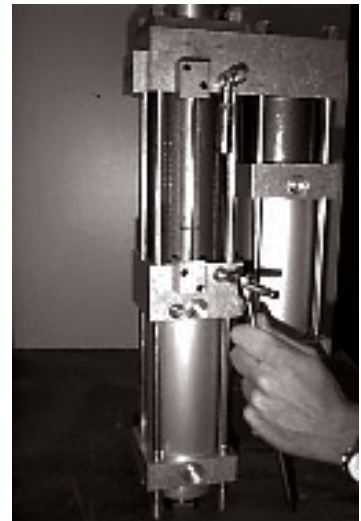

AX Unit User and Maintenance Manual

SPECIAL MAINTENANCE

Special maintenance is foreseen when the following operational faults occur:

- Excess oil consumption requiring more frequent topping up operations than normally foreseen.
- Signs of oil leakage to outside.
- Work stroke fails to start up.

Any air or oil leakages resulting from worn joints may be detected through the inspection hole located right under the filling line, with the possibility of scheduling maintenance.

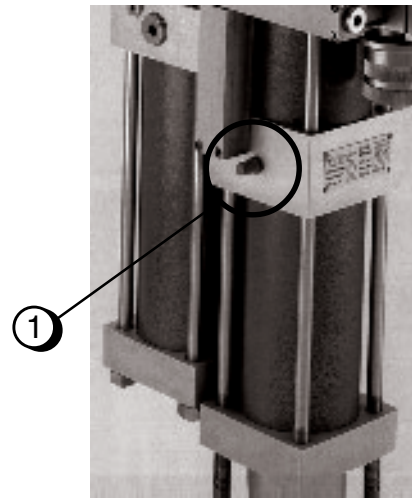

Perform the following operations before arranging for the replacement of all joints:

- If there is external leakage, clean the unit and replace the joint in question after verifying the point of leakage.
- If the work stroke does not couple, check the correct operation of system engineering.

Procedure for Replacing Joints

- 1) All the joints of the AX power unit must be removed from their seats with a tool that allows this operation to be performed without damaging their seats. Any dents produced by inappropriate tools could compromise the tightness of joints.
- 2) The new joints may be installed without using any tool. Simply apply slight pressure with one's hand to ease the joint into place on the appropriate slot. Use of inappropriate tools could damage joints compromising their capacity to guarantee tightness.
- 3) Before installing any joint (except for the OR-ring), it is essential to know the direction in which each is to be installed. Verify the direction of each joint by referring to the diagram indicated below. The installation of the joint in the opposite direction would make it ineffective.

AX Type Unit Maintenance Manual

Seals mounting schema for unit AX0840 - AX0950

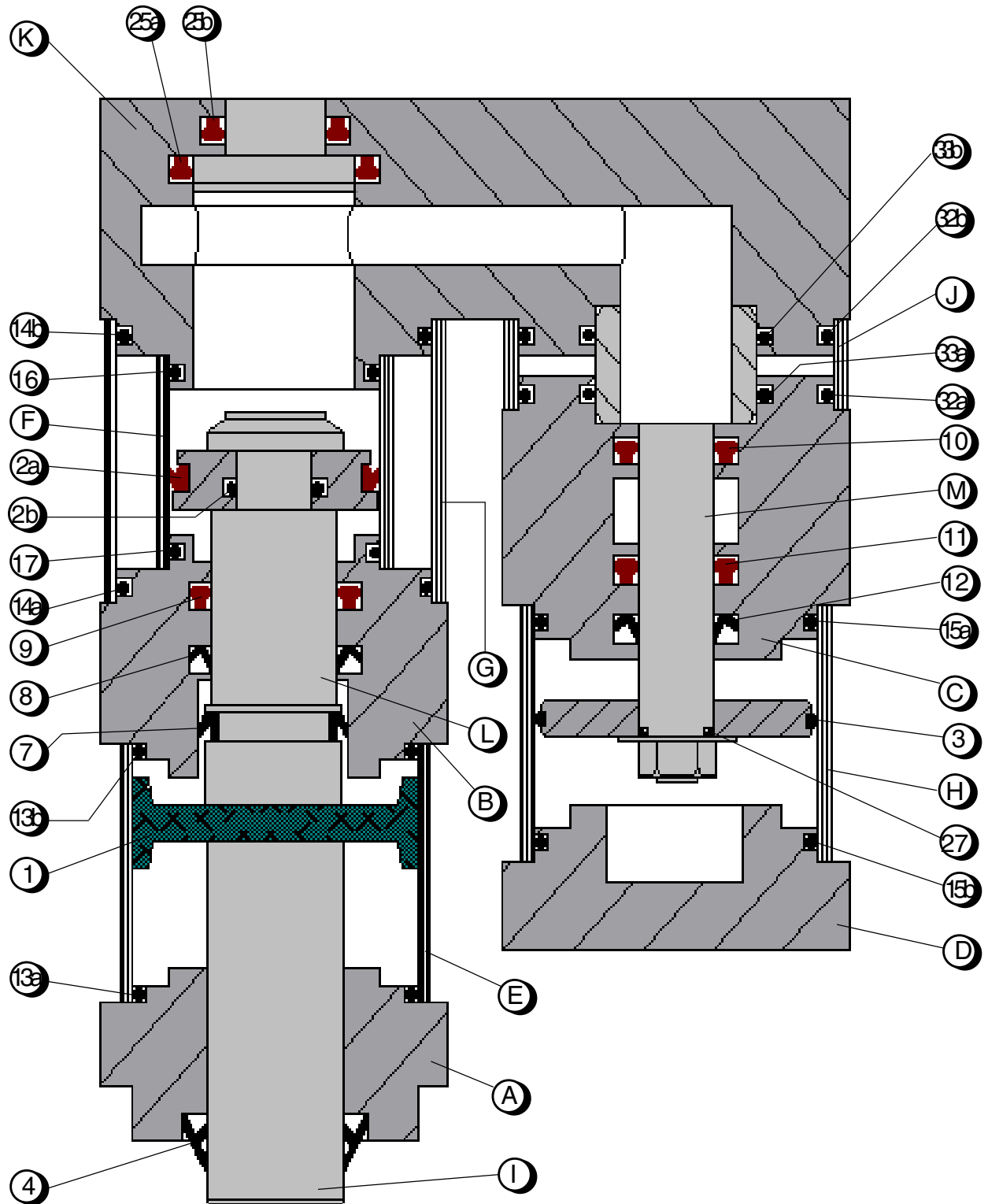

AX Type Unit Maintenance Manual

Procedure for Replacing AX 0840 - AX 0950 Joints

- 1) Eliminate pressure from unit.
- 2) Bleed off residual pressure from the unit following the procedure indicated on page 4.
- 3) Let all oil flow out of the unit following the procedure indicated on page 4.
- 4) Unscrew the eight nuts locked on the tie rods located on the dual body (pos. K).
- 5) Slip tie rods from unit.
- 6) Remove the front head (pos. A) pulling it through the rod.
- 7) Free the circlip that secures the NIPSL to the front head using appropriate pliers, then replace both the NIPSL (pos. 4) and the OR-ring (pos. 13a) with front lining.
- 8) Pull out the front lining (pos. E).
- 9) Remove the unit's circuits by unscrewing the appropriate fixing screws.
- 10) Remove the lower body (pos. 8) by separating it from the intermediate linings (pos. F-G). If mechanically adjusted, proceed first to disassemble the lining following the procedure shown on page 29.
- 11) Free the front piston (pos. 1) by unscrewing the front rod (pos. 1) from the intermediate rod (pos. L), and replace it. Before unscrewing rods, make sure to remove mechanical locking elements such as pins or sprigs.
- 12) Free the intermediate piston by unscrewing the collar that secures it to the intermediate rod and replace the OR piston-rod retaining ring (ps. 2b) and the MAD (pos. 2a).
- 13) Slip the intermediate rod (pos. 1) from the lower body (pos. B) pulling it out from the front and replace the DE (pos. 7).
- 14) Pull out the intermediate lining (pos. F-G).

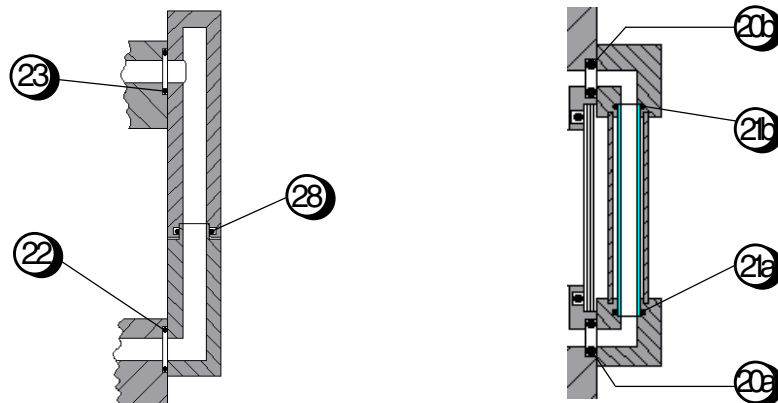

AX Type Unit Maintenance Manual

- 15) In the lower body (pos. B), replace both OR retaining rings and linings (pos. 13b-14a) and the circuit retaining rings (pos. 20a-22). Also replace the CSC (pos. 9) and the NI (pos. 8).
- 16) Remove the dual body (pos. K) from the rest of unit pulling it out from the multiplier (pos. J) tank lining. If the unit disposes of mechanical adjustment (optional), replace the CSC (pos. 25a-25b-25c) as indicated on page 29. If not mechanically adjusted, remove the appropriate plug in order to replace the CSC (pos. 25a-25b). Also replace the OR retaining ring with circuits (pos. 20a-23).
- 17) Slip out the pressure multiplier body (pos. C) of the rod (pos. M) and of the multiplier lining itself (pos. H) and replace the OR retaining rings with linings (pos. 15a-32a-33a). Then replace the retaining CSC with the multiplier rod (pos. 10-11) and the NI (pos. 12).
- 18a) For the AX 0950 model only) Free the pressure multiplier piston from the rod and replace it (pos. 3).
- 18b) (For the AX 0840 model only) Unscrew the nut that secures the pressure multiplier piston to the relative rod and replace the OR retaining ring (pos. 27). Replace the piston's OR ring (pos. 3).

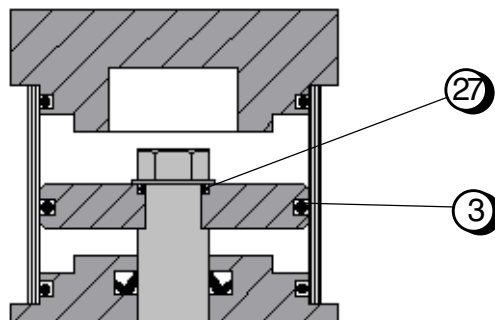

- 19) Replace the OR retaining ring and linings (pos. 15b) on the rear head (pos. D).
- 20) Separate the oil level pipe and relative protection from the unit's anchoring flange and replace both OR retaining rings (pos. 21a-21b).
- 21) Separate the oil filling line pipes and replace the OR retaining ring (pos. 28).
- 22) Go through the disassembling phase in the reverse order to reassemble the unit, remembering to tighten the tie rod nuts according to the cross-tightening procedure

AX Type Unit Maintenance Manual

Seals mounting schema for unit AX1063 - AX1180 - AX12100 - AX13125

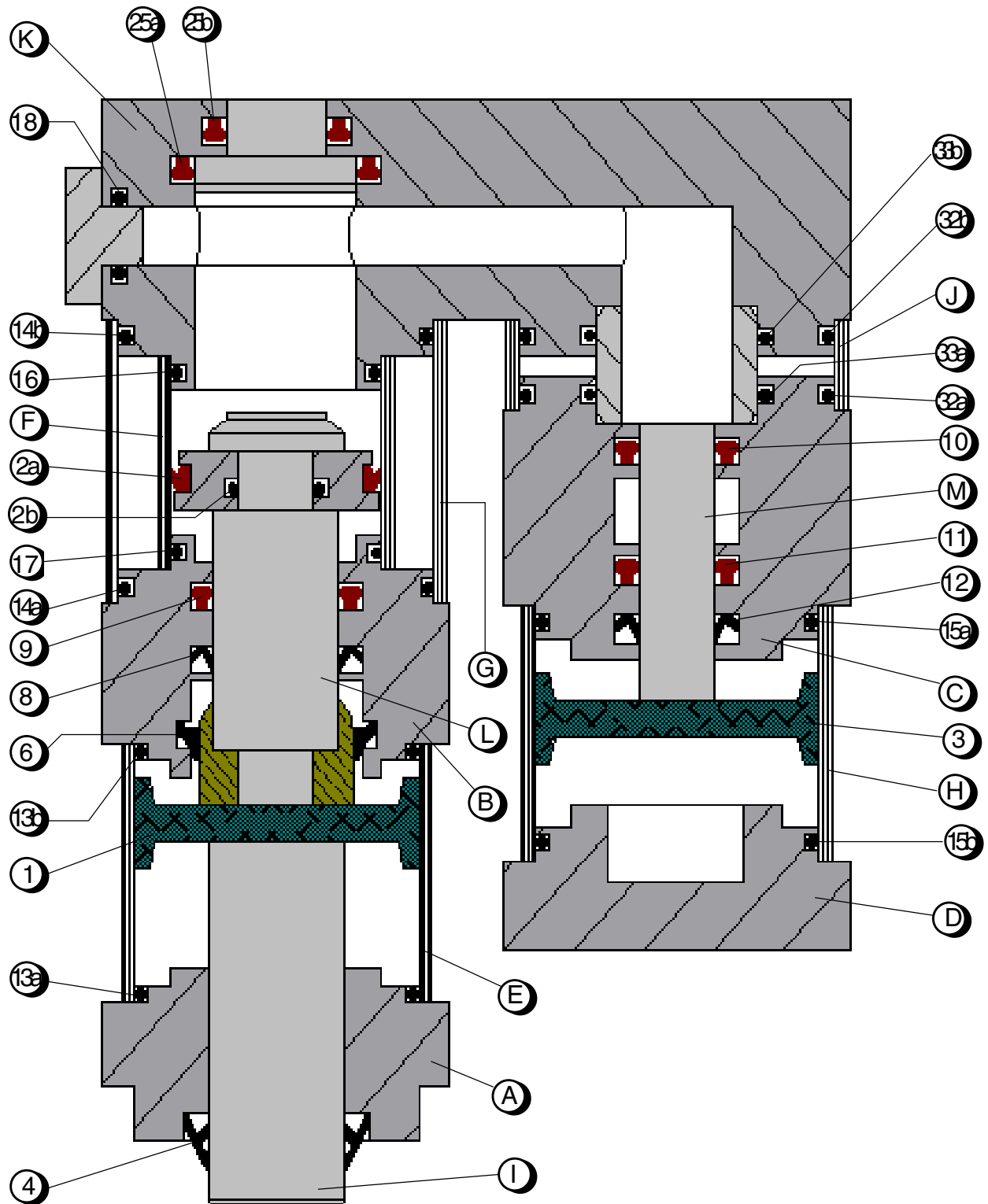

AX Type Unit Maintenance Manual

Procedure for replacing joints on AP1063 - AP1180 - AP12100 - AP-13125

- 1) Eliminate pressure from unit.
- 2) Bleed off residual pressure from unit as indicated on page 4.
- 3) Let all the oil in unit flow out as indicated on page 4.
- 4) Unscrew the nuts tightened on the tie rods of the dual body (pos. K).
- 5) Slip out the unit's tie rods.
- 6) Remove the front head (pos. A) letting it slip onto rod.
- 7a) (For AX 1063 and AX 1180 models only) Free the circlip that secures the NIPSL to the front head with appropriate pliers, then replace both the NIPSL (pos. 4) and the OR retaining ring (pos. 13a) and front lining.
- 7b) (For AX12100 and AX13125 models only) With the help of a screwdriver or other tool, remove the AS rod scraper (pos. 4). During the installation of the new joint, make sure the AX 12100 is equipped with an external perimetral ring which must be forced slightly into its seat. The AP 13125 instead foresees a RGS rod scraper (pos. 4) with installation procedure similar to that of the other joints. Replace the NI (pos. 5) and the OR retaining ring (pos. 13a) with front lining.

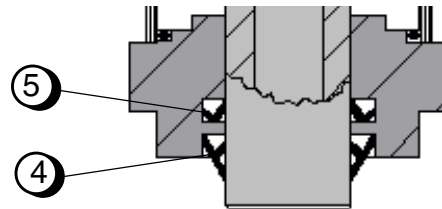

- 8) Slip out the front lining (pos. E).
- 9) Remove the load circuit and the oil level indicator circuit by loosening the screws that secure them to the unit bodies.
- 10) Remove the lower body (pos. B) and separate it from the intermediate lining (pos. F-G). When mechanically adjusted, first proceed to disassemble the intermediate lining by following the procedure indicated on page 29.
- 11a) (For AX1063, AX1180 and AX12100 models only) Free the front piston (pos. 1) by unscrewing the front rod (pos. 1) from the intermediate rod (pos. L) and replace it. Before unscrewing rods, be sure to remove the mechanical retaining elements such as pins or sprigs.

AX Type Unit Maintenance Manual

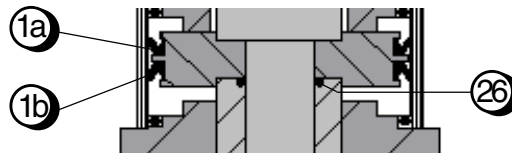

12) Free the intermediate piston by unscrewing the ring that secures it to the intermediate rod and replace the OR piston-rod retaining ring (pos. 2b) and the MAD (pos. 2a).

13) On the lower body (pos. B), replace the three OR retaining rings with linings (pos. 13b-14a-17) [only 13b-14a for the AP1063 model] and both OR retaining rings with circuits (pos. 20a-22). Also replace the CSC (pos. 9) and the NI (pos. 8)

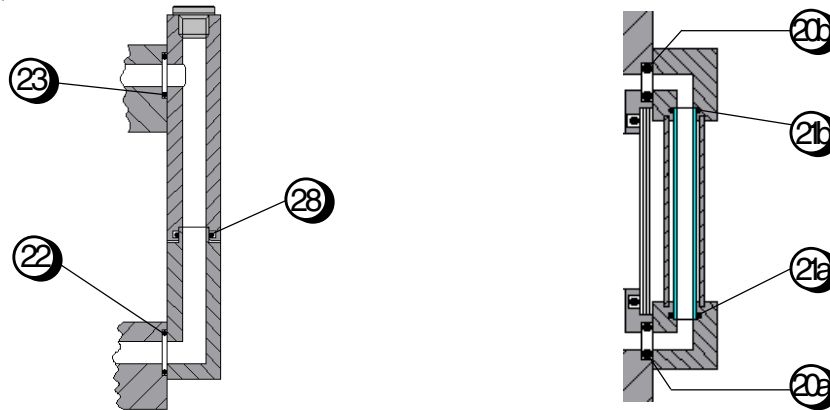

14) Slip off the intermediate linings (pos. F-G).

15) Remove the dual body (pos. K) from the rest of the unit by slipping it out of the multiplier tank lining (pos. 3). If the unit disposes of mechanical adjustment (optional), replace the CSC (pos. 25a-25b-25c) according to the procedure indicated on page 29. If not mechanically adjusted, replace the appropriate plug to replace the CSC's (pos. 25a-25b). Replace the OR retaining ring with circuits (pos. 20a-23). Also replace the OR retaining ring and any pressure relief valve (optional) (pos. 18).

16) Slip the multiplier body (pos. C) from the rod (pos. M) and from the multiplier lining (pos. H) and replace the three OR retaining rings and linings (pos. 33a-32a-15a) as well as the two CSC (pos. 10-11) retaining rings with the multiplier rod and the NI (pos. 12).

17) Free the pressure multiplier piston from the rod and replace it (pos. 3).

18) Replace the OR retaining ring with lining (pos. 15b) on the multiplier head (pos. D).

19) Separate the oil level pipe with relative protection from the flanges for anchoring to unit, and replace both OR retaining rings (pos. 21a-b).

AX Type Unit Maintenance Manual

Schema di montaggio guarnizioni unità AX14160 - AX15200 - AX16200

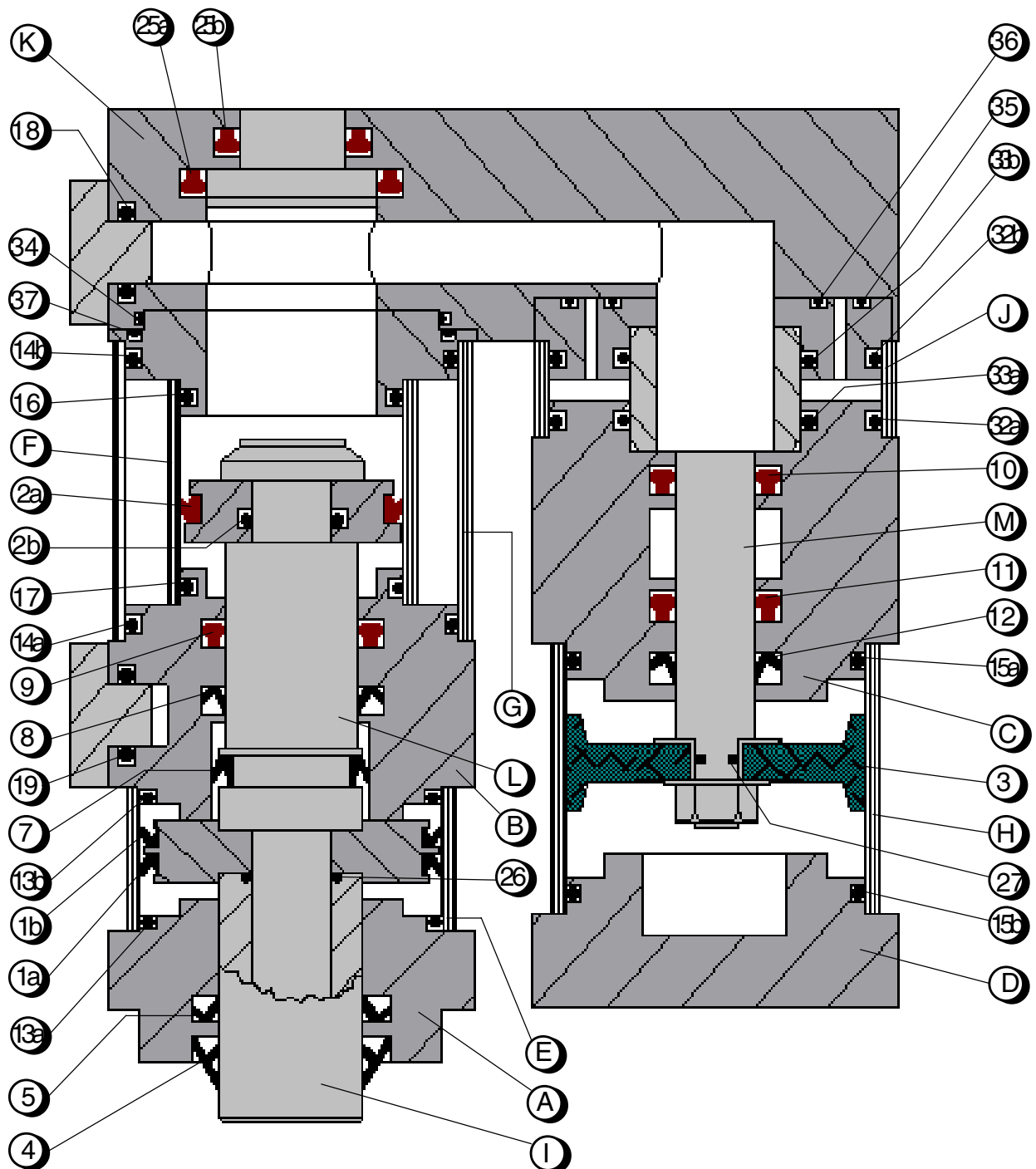

AX Type Unit Maintenance Manual

Procedura di sostituzione guarnizioni per AX 14160 - AX15200 - AX 16200

- 1) Depressurize unit.
- 2) Discharge any remaining pressure from the unit according to the procedure set out on page 4.
- 3) Let all the oil in the unit flow out according to the procedure set out on page 4.
- 4) Unscrew the eight nuts on the tie-rods by the double body (pos. K).
- 5) Extract tie rods from unit.
- 6) Remove front head (pos.A) by extracting it from the stem.
- 7) Remove and replace stem scraping RGS (pos.4). Then replace NI (pos 5) and sealing O-ring (pos.13a) with front liner On AX 16200 models release front front head the relevant flange (pos.T) by unscrewing fixing socket head screws , then replace sealing O-ring (pos.38)

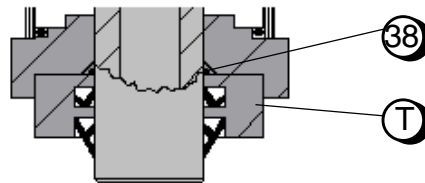

- 8) Extract front liner (pos.E).
- 9) Remove oil loading and level circuits by unscrewing the screws fixing them to the unit bodies.
- 10) Remove lower body (pos.B) by separating it from the intermediate liners (pos.F-G).In presence of a mechanical regulation device, first disassemble the latter following the instruction on page 29.
- 11) After removing locking dowel, release front piston by unscrewing front stem (pos.l) from the intermediate stem (pos.L) , then replace the two DEM (pos.1a-1b) installed on the steel piston and the stem-piston sealing O-ring (pos.26).
- 12) Release intermediate piston by unscrewing the ring nut fixing it to the intermediate stem and replace piston-stem sealing O-ring (pos 2b) and MAD (pos.2a)
- 13) Extract intermediate stem (pos.L) from lower body (pos.B) by extracting it from the front part and replace NA (pos.7)
- 14) Replace from lower body (pos.B) the three sealing O-rings with liners (pos. 13b-14a-17) and the two sealing O-rings with circuits (pos 20a-22) .Also replace CSC (pos.9),NI (pos.8) and if there is no modulating valve, outlet O-ring (pos. 19) [For AX 14160 AX15200 models only].
- 15) Extract intermediate liners (pos.F-G).
- 16) Remove the double body (pos.K) from the rest of the unit, removing it from the multiplier tank jacket (pos. J). If the unit has a mechanical regulation device (optional) replace the CSC (pos. 25a-25b-25c) following the instructions on page 29. If there is no mechanical regulation device remove the special plug to replace the CSC (pos. 25a-25b). Replace the sealing OR with the circuits (pos. 20a-23). Also replace the sealing OR with the limiter valve, (optional) if present (pos. 18).

AX Type Unit Maintenance Manual

- 17) Separate the flange which connects the multiplier tank-jacket (pos. J) from the double body and replace the sealing OR (pos. 34-35-32a-33a).
- 18) Separate the flange which connects the intermediate stage jacket (pos. F-G) from the double body and replace the sealing OR (pos. 34-37-16-14b).
- 19) Remove the pressure multiplier tank-jacket (pos. J) from the body of the multiplier (pos. C).
- 20) Remove the multiplier body (pos. C) from its stem (pos. M) and replace the sealing OR with the jackets (pos.32a-33a-15a), the CSC (pos. 10-11) and the NI(pos. 12).
- 21a) [For AX 14160 AX 15200 models only] Release pressure multiplier piston (pos.3) from relevant stem and replace it. Also replace stem-piston sealing O-ring (pos.27)
- 22b) [For AX 16200 model only] Extract lower pressure multiplier liner (pos.P) and remove back head (pos.D) with relevant liner (pos.H), then release lower multiplier piston (pos.3) by unscrewing lower stem (pos.M) from the upper stem (pos.N). Then separate upper multiplier piston from relevant stem by unscrewing the nut fixing it . Remove from the intermediate body of the pressure multipliers (pos.Q) the two sealing O-rings with liners (pos.29a-b) and the two NI (pos.30a-b)

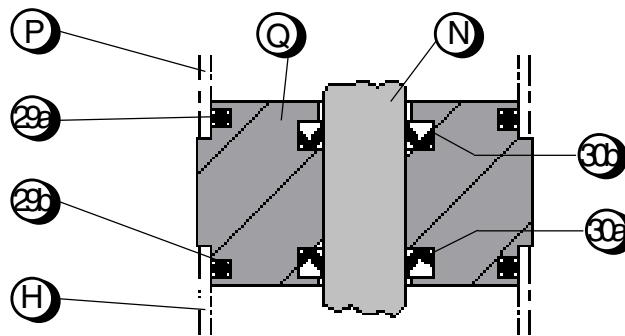

- 22) Replace from back head (pos.D) sealing O-ring with liners (pos.15b)
- 23) Separate oil level pipe with relevant protection from flanges fixing it to unit and replace the two sealing O-rings (pos.21 a-b).
- 24) Separate oil loading pipe from relevant flanges and replace the two sealing O-rings (pos.24 a-b).

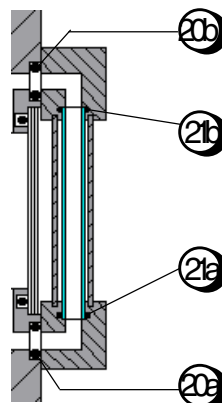

AX Type Unit Maintenance Manual

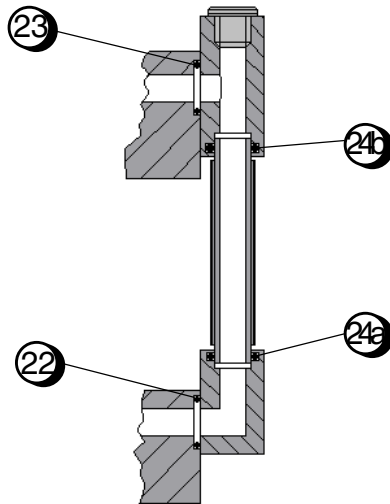

- 25) Remake disassembly phases in the opposite sequence to re-assemble unit and cross tighten tie rod nuts.

AX Unit User and Maintenance Manual

Gasket replacement on AX0840 - AX0950 unit pressure relief valves

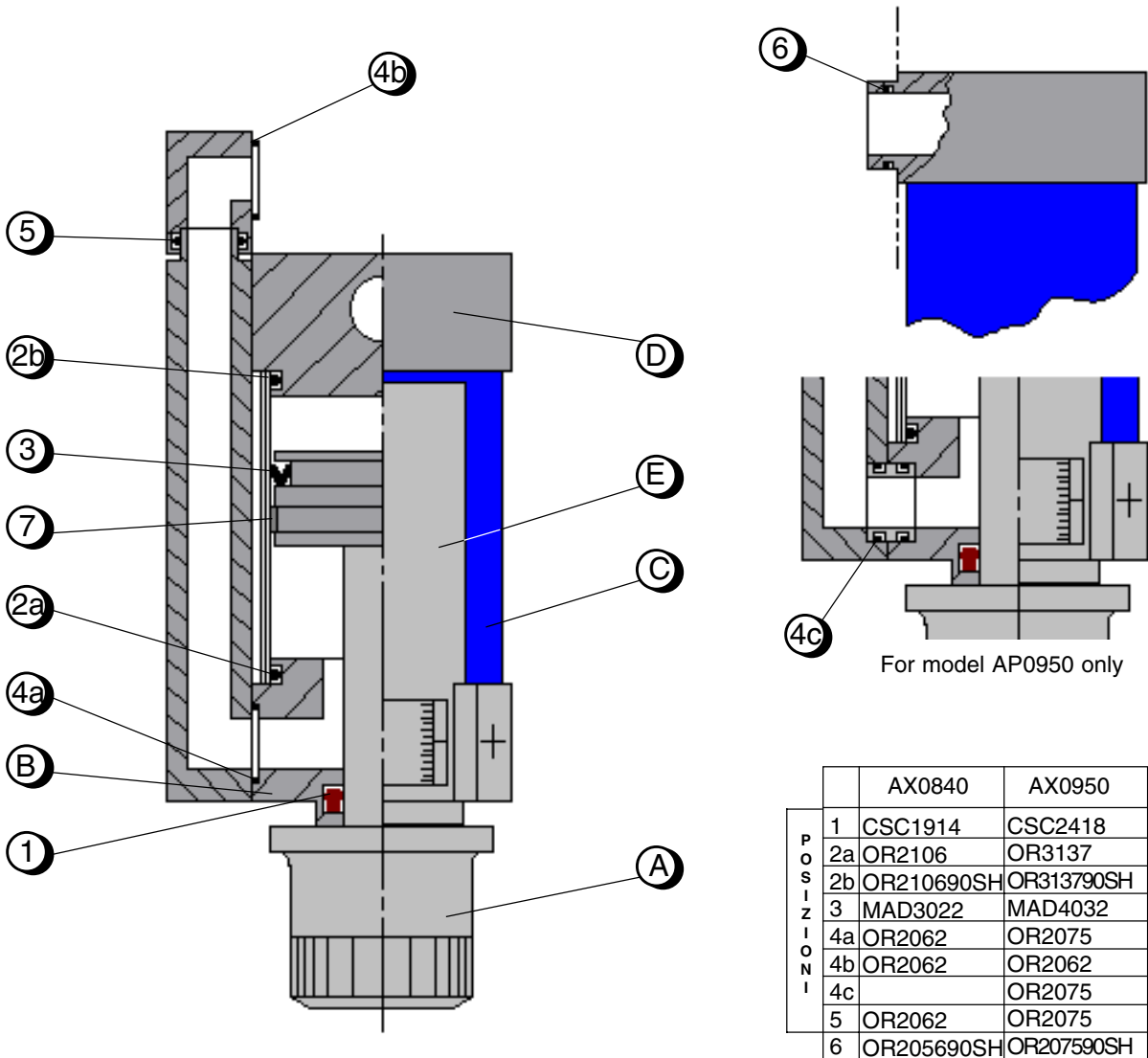

- 1) Detach the pressure relief valve from the oil circuit and the unit's body by loosening the appropriate fastening screws.
- 2) Remove the mechanical stop (circlip) on the adjustment knob (pos. A) and unscrew the knob until it is detached from its stem.
- 3) Unscrew the four tie rods that keep the valve assembly together.
- 4) Pull out the front part of the valve body (pos. B) and replace the CSC (pos. 1), the O-ring seal (pos. 2) to sleeve (pos. C) and the O-ring seal to oil circuit (pos. 4a) [For the AP 0950 model, also replace the second O-ring seal to circuit (pos. 4c)].
- 5) On the valve piston (pos. E), replace the CSC (pos. 3) and the guide tape (pos. 7).
- 6) Pull out the sleeve from the rear of body (pos. D) and replace the O-ring seal to the sleeve (pos. 2b) and the one to the unit body (pos. 6), respectively.
- 7) Divide the oil circuit and replace the O-ring seal (pos. 5 and 4b)

AX Unit User and Maintenance Manual

Gasket replacement on AX1063 - AX1180 - AX12100 - AX 13125 unit pressure relief valves

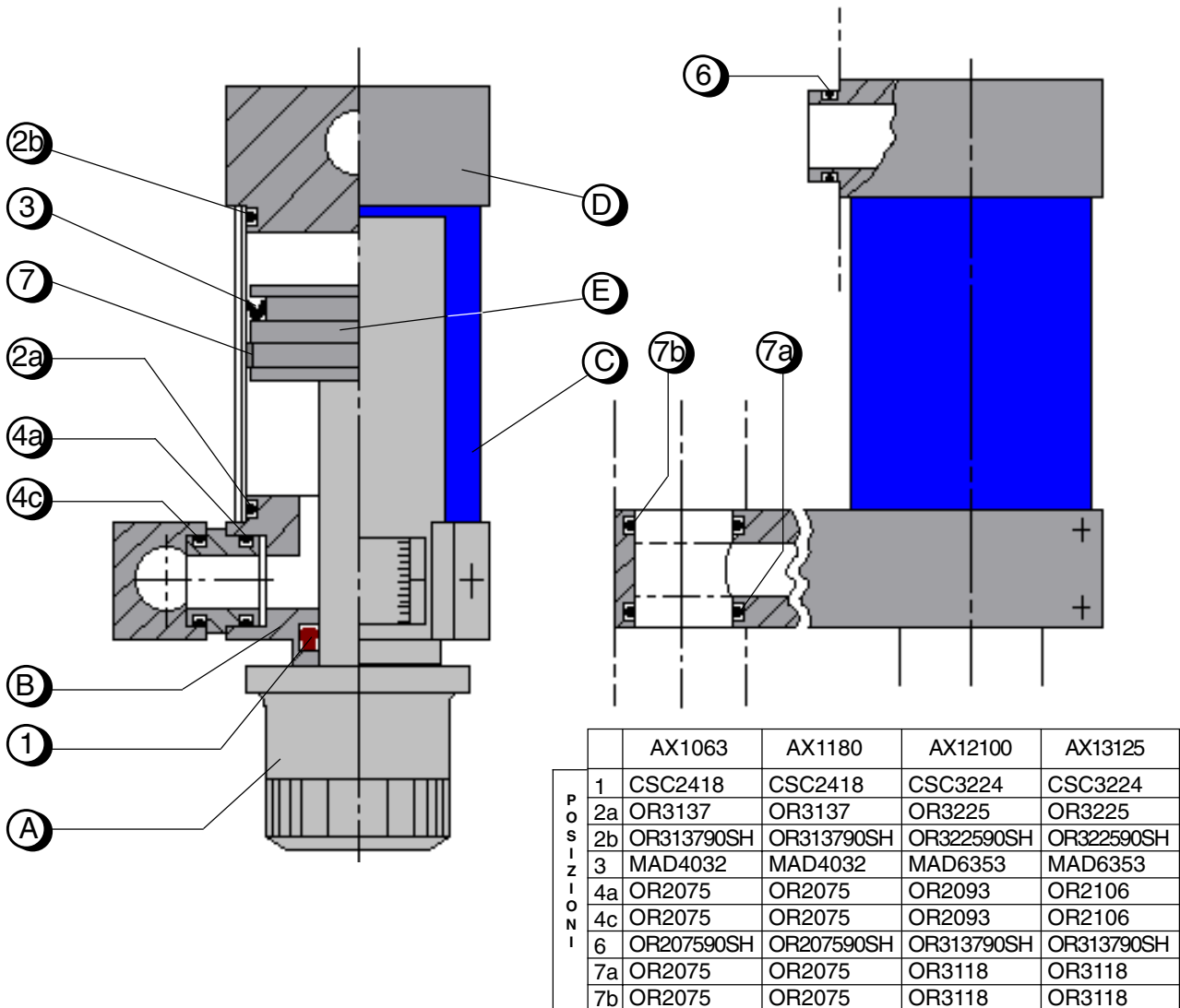

- 1) Detach the pressure relief valve from the oil circuit and from the unit's body by unscrewing the appropriate fastening screws.
- 2) Remove the mechanical stop (circlip) from the adjustment knob (pos. A) and unscrew the knob until it is detached from its stem.
- 3) Unscrew the four tie rods that hold the valve assembly together.
- 4) Pull out the front part of the valve body (pos. B) and replace the CSC (pos. 1), the O-ring seal (pos. 2a) to sleeve (pos. C) and the O-ring seal to oil circuit (pos. 4a).
- 5) On the valve piston (pos. E), replace the CSC (pos. 3 and the guide tape (pos. 7).
- 6) Pull out the sleeve from the rear of body (pos. D) and replace the O-ring seal to sleeve (pos. 2b) and the one to the unit's body (pos. 6), respectively.
- 7) Divide the oil circuit and replace the O-ring seals (pos. 4c-7a-7b).

AX Unit User and Maintenance Manual

Gasket replacement on AX14160 - AX15200 unit pressure relief valves

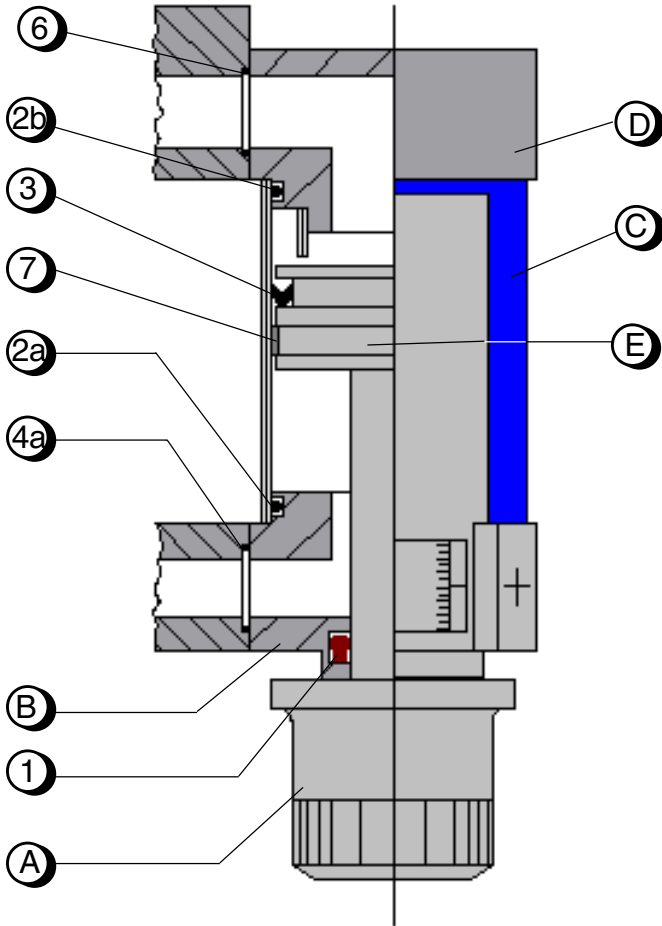

	AP14160	AP15200	
P O S I T I O N	1	CSC3830	CSC3830
	2a	OR3225	OR3225
	2b	OR322590SH	OR322590SH
	3	MAD6353	MAD6353
	4a	OR3125	OR3125
	6	OR312590SH	OR312590SH

- 1) Detach the pressure relief valve from the oil circuit and the unit's body by unscrewing the appropriate fastening screws.
- 2) Remove the mechanical stop (circlip) on the adjustment knob (pos. A) and unscrew the knob until it is detached from its stem.
- 3) Unscrew the four tie rods that hold the valve assembly together.
- 4) Pull out the front part of valve body (pos. B) and replace the CSC (pos. 1), the O-ring seal (pos. 2a) to sleeve (pos. C) and the O-ring seal to the oil circuit (pos. 4a).
- 5) On the valve piston (pos. E), replace the CSC (pos. 3) and the guide tape (pos. 7).
- 6) Pull out the sleeve from the rear of body (pos. D) and replace the O-ring seal to the sleeve (pos. 2b) and the one to the body (pos. 6), respectively.

Gasket replacement on mechanical adjustment

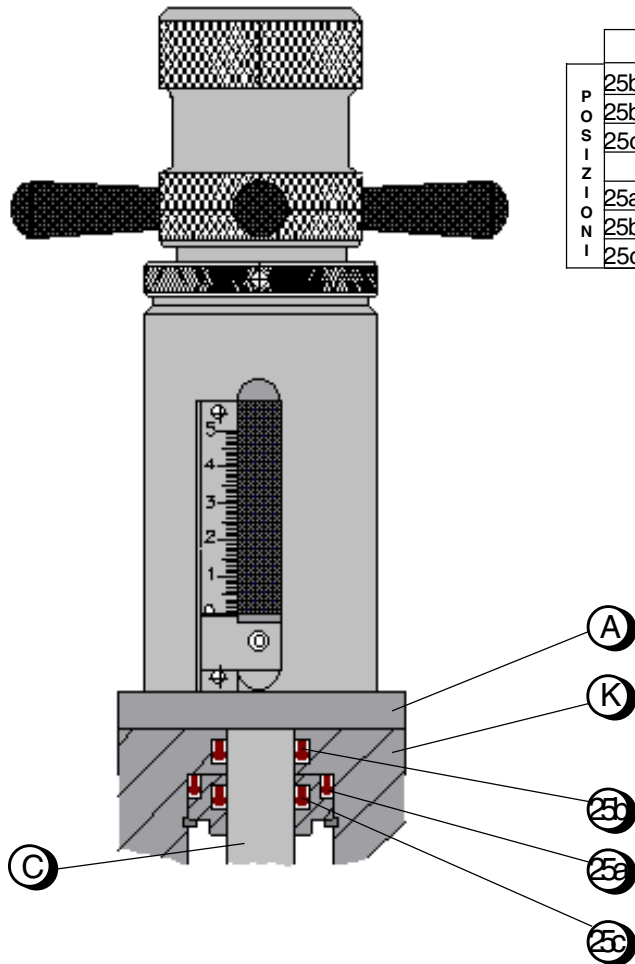

	AX0840	AX0950	AX1063	AX1180	
P O S I T I O N	25b	CSC1914	CSC3224	CSC4032	CSC4537
	25b	CSC1510	CSC1812	CSC2618	CSC3022
	25c	MAD1610	MAD1812	MAD2618	MAD3022
		AX12100	AX13125	AX14160	AX15200
	25a	CSC7060	CSC7060	CSC8068	CSC9080
	25b	CSC4636	CSC4636	CSC6050	CSC7060
25c	MAD4636	MAD4636	MAD6050	MAD7060	

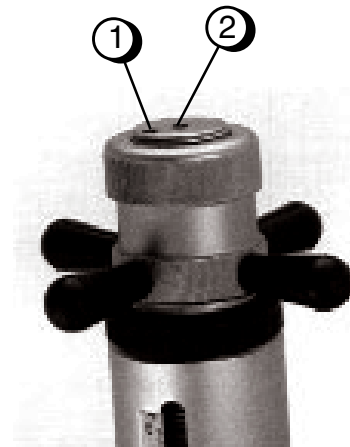

- 1) Unscrew the lock bolt on the P.M.S. (pos. 1) adjustment ring nut, unscrew the ring nut and remove it from its seat (pos. 2).
- 2) Unscrew the four screws that hold the mechanical adjustment flange (pos. A) to the double body (pos. K), and remove the entire adjustment block from the unit.
- 3) Replace the CSC (pos. 25b), after removing the double body from the unit, according to the instructions given in the sections dedicated to this operation. Remove the circlip for clamping the bronze bearing on the mechanical adjustment stem and replace the CSC and the MAD (pos. 25a-25b).
- 4) Re-assemble the unit in the reverse order of that indicated above.

AX Unit User and Maintenance Manual

		MODELLI UNITA' SERIE AX								
		AX 0840	AX 0950	AX 1063	AX 1180	AX 12100	AX 13125	AX 14160	AX 15200	AX 16200
P O S I Z I O N I	1	DKM054009	DKM055010	DKM056316	DKM058016	TDUOP10069				
	1a / 1b						DEM125	DEM160	DEM200	DEM200
	2a	M43224	MAD4032	MAD504075	MAD504075	MAD8065	MAD8065	MAD10085	MAD10085	MAD125-110
	2b	OR2075	OR2075	OR3106	OR3106	OR3125	OR3125	OR3162	OR3162	OR3206
	3	OR4131	DKM055010	DKM056312	TDUOP8073	TDUOP10069	TDUOP12551	TDUOP16025	TDUOP20025	TDUOP20025
	4	NIPSL22327	NIPSL22327	NIPSL30407	NIPSL40507	AS60707	RGS8088	RGS100108	RGS100108	RGS100108
	5					NI150607285	NI150809285	NI1501001151	NI1501001151	NI1501001151
	6			PPP894050	PPP894050		PPP895060			
	7	DE093	DE100					DEM63	DEM63	NA325
	8	DI087	DI093	NI15030407	NI5030407	NI15040507	NI15040507	NI150607285	NI150607285	NI150809285
	9	CSC3022	CSC3224	CSC3830	CSC3830	CSC5040	CSC5040	CSC7060	CSC7060	CSC9080
	10	CSC1812	CSC2416	CSC2618	CSC2416	CSC3224	CSC3224	CSC3830	CSC3830	CSC4636
	11	CSC1812	CSC2416	CSC2618	CSC2416	CSC3224	CSC3224	CSC3830	CSC3830	CSC4636
	12	NI150122055	NI150162455	DI068	NI150162455	DI093	DI093	NI15030407	NI15030407	NI15036467
	13a / 13b	OR3137	OR3175	OR3225	OR176	OR4362	OR4462	OR4600	OR235	OR235
	14a / 14b	OR3156	OR3193	OR3256	OR176	OR4425	OR4462	OR4600	OR235	OR235
	15a / 15b	OR3137	OR3175	OR3225	OR176	OR4362	OR4462	OR4600	OR235	OR235
	16	OR2112	OR3137	OR317590SH	OR317590SH	OR433790SH	OR433790SH	OR446290SH	OR446290SH	OR446290SH*
	17	OR2112	OR3137	OR3175	OR3175	OR176	OR176	OR4362	OR4362	OR4462
	18			OR207590SH	OR207590SH	OR313790SH	OR313790SH	OR312590SH	OR312590SH	
	19							OR3125	OR3125	
	20a	OR2043	OR2056	OR2056	OR2056	OR2056	OR2056	OR2056	OR2056	OR2056
	20b	OR2062	OR2056	OR2056	OR2056	OR2056	OR2056	OR2056	OR2056	OR2056
	21a / 21b	OR2037	OR114	OR114	OR114	OR114	OR114	OR114	OR114	OR114
	22	OR2050	OR2068	OR2068	OR2068	OR2106	OR2106	OR2106	OR2106	OR2106
	23	OR2050	OR2068	OR2068	OR2068	OR2106	OR2106	OR2106	OR2106	OR2106
	24a / 24b							OR3106	OR3106	OR3106
	25a	CSC1914	CSC3224	CSC4032	CSC4537	CSC7060	CSC7060	CSC8068	CSC9080	
	25b	CSC1510	CSC1812	CSC2618	CSC3022	CSC4636	CSC4636	CSC6050	CSC7060	
	26						OR2093	OR3143	OR3143	OR3193
	27	OR2031						OR2062	OR2062	OR2062
	28	OR2050	OR3075	OR2075	OR2075	OR3118	OR3118			
	29a / 29b									OR4750
	30a / 30b									NI15036467
	31									
	32a / 32b	OR3137	OR3175	OR3225	OR176	OR4362	OR4462	OR4600	OR235	OR235
	33a / 33b	OR123	OR3093	OR310690SH	OR310690SH	OR315090SH	OR315090SH	OR315090SH	OR315090SH	OR318790SH
	34							OR446290SH	OR446290SH	OR425090SH*
35							OR4562	OR4725	OR4725	
36							OR417590SH	OR417590SH	OR4420090SH	
37							OR3650	OR3800	OR3800	
38									OR4462	

Sensor characteristics for magnetic versions of unit

ELECTRICAL	
	DATA
Operating voltage	U_{min} 15 V =
	U_{max} 30 V =
Charging current	I_{max} 800 mA
Operating current	disconnected 14 mA
	connected 25 mA
Electrical connection	PG9 connection at 3 poles
Protection	IP65, polarity reversal protection, operating voltage, protection insulation